

SOLAR MOUNTING SOLUTION FOR SLATE ROOFS



A-SLATE

DESIGNED BY INSTALLERS, FOR INSTALLERS.

The A-Slate is the discreet easy way to swiftly mount on-roof solar systems to any slate roof. Designed by installers, for installers, it can be installed in a few easy steps. With a 12-year durability warranty and full MCS accreditation, you can ensure that your solar system will be safely secured onto any slate rooftop.

**The only MCS dedicated roof anchor hook.
The MCS number is MCS IK0251/04.**

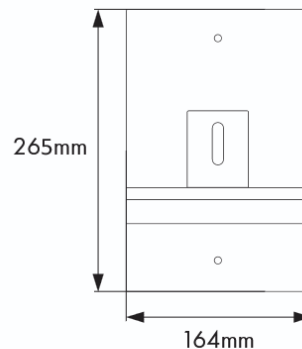

FEATURES

- Suitable for pitched roofs
- Cladding type: Slate
- Maximum slope: 60 degrees
- Wind load: up to 60m/s
- Snow load: 2.0kn/m²
- Maximum building height: 20m
- Material: AL6005&Stainless steel
- MCS 012 certification
- Quick and simple solar installations on slate roofs. No cutting, and no leaks.
- Warranty: 12 years durability on material, 5 years on finish

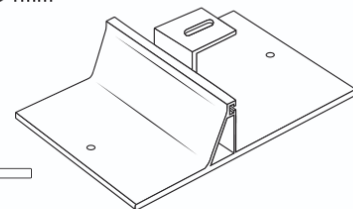
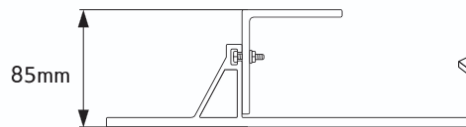

TECHNICAL SPECIFICATION



MCS 012 - Pitched Roof Installation Kits - Issue 2.4		
Product Name	Description	Reference No.
A-SLATE	Above Roof Component	MCS IK0251/04
System information:		
Weatherightness		
Compatible roof coverings	Slates	
Minimum permissible roof pitch	15°	
Resistance to Wind Uplift		
Compatible roof substrates	Timber (50mm minimum rafter or batten thickness)	
Test set up	Component test - 1 A-Slate base (FSD460) including L-bracket (FSD461) attached with 2x6.5*100mm screws (FSD465) on to ungraded timber with slate roof covering	
Maximum design wind uplift resistance	4928.5 N per bracket	
Partial safety factor	1.1	
Fire Performance		
Fire classification	Not applicable	
Fire classification achieved with	Not applicable	
Certificated Components:		
A-Slate base [265*164*5mm] (FSD460)	Neoprene gasket [265*164*2mm] (FSD464)	
A-Slate L-bracket (FSD461)	Screw [6.5*100mm] (FSD465)	
L-bracket nut (YGG123937)	Nylon spacer [20mm, 10mm OD, 8.2mm ID] (Spacer)	
L-bracket bolt [A2 M8*25mm] (YGG100048)	C-Tec CT1 sealant (CT1 sealant)	